

Pre-engineered Systems

Dual pump

Pre-engineered solutions!



ProMinent®

ProMinent® is your sole source provider for complete chemical metering systems. The heart of every system is the metering pump. ProMinent® metering pumps are the best engineered and most reliable in today's market. In addition, every system is engineered and designed from the ground up.

Pre-engineered systems are fully assembled and tested; guaranteeing a fully functional and high quality system package upon delivery.

*Dual pump designs accommodate **Beta®**, **Gamma/ L**, **delta®**, and **Sigma** series pumps. Feed rates up to 264 gph (1000 l/h).*

Features & Benefits

- Plug & Play for quick and easy installations
- Lead times as short as 1-3 weeks
- Designs for handling off-gassing chemicals
- Easy access to pump liquid end for on-site repair and retrofitting
- Optional UL listed and labelled control panels (US)
- Proven design based on 10+ years of experience

Pre-engineered Systems

Dual pump

Solutions that work!

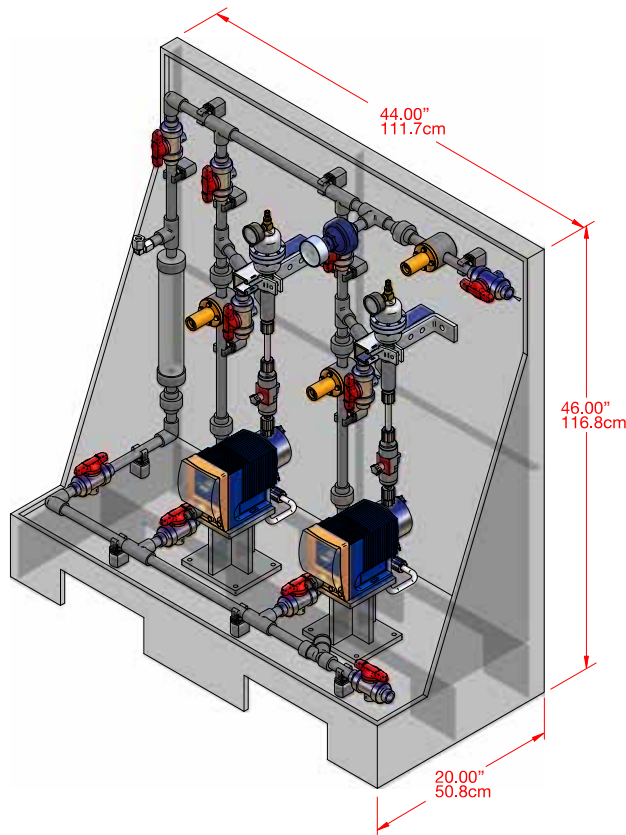

SS2: for Beta®, Gamma/ L, and delta® series pumps

Drawings depict item #4 described below

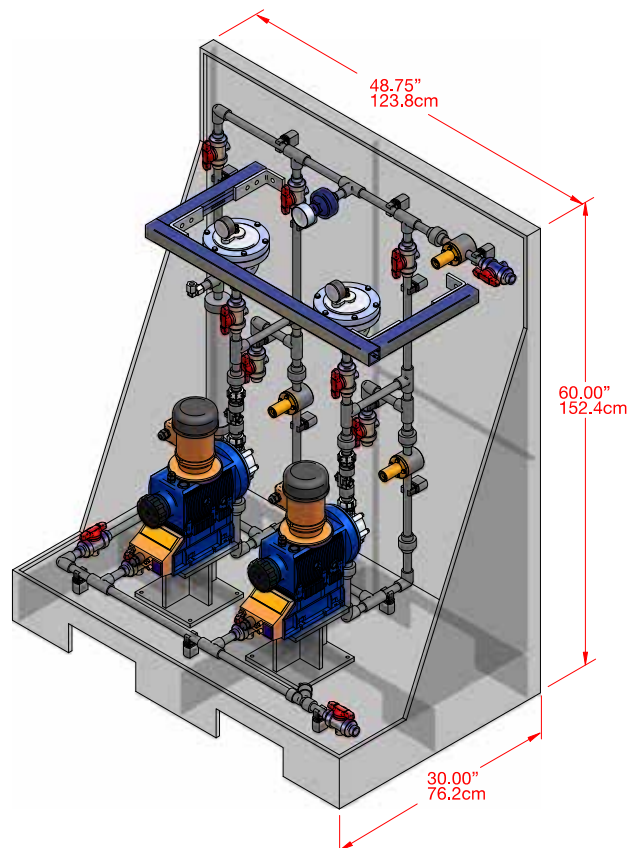

MS2: for Sigma/ 1, Sigma/ 2 and Sigma/ 3 series pumps

Standard Skid Packages, Sizes and Material Configurations

Standard Skid Packages:

1. Wye Strainer, Calibration Column, Backpressure Valve, Pressure Relief Valve, Pressure Gauge (motor skids must have dampener)
2. ALL OF THE ABOVE + Flow Monitor
3. ALL OF THE ABOVE + Pulsation Dampener
4. ALL OF THE ABOVE + Flow Monitor & Pulsation Dampeners

Sizes:

- SS2: 1/2" MNPT
- MS2: 1/2" MNPT
3/4" MNPT
1" MNPT
1-1/2" MNPT

Materials:

- PVC/Viton® (socket weld)
- PVC/EPDM (socket weld)
- CPVC/Viton®/Vented (socket weld)
- PVDF/PTFE (fusion weld)