

NIKKISO Non-Seal[®] Pump

Canned Motor Pumps





NIKKISO Non-Seal® Pumps

Nikkiso began production of canned motor pumps in 1953, making us one of the first companies to produce canned motor pumps commercially in the world.

Originally designed for the nuclear industry, canned motor pumps over the years have been developed and adapted to a wide variety of industrial services. Nikkiso has been at the forefront of those developments since its founding. The E-Monitor bearing monitoring system is the most advanced device of its kind in the industry.

Advantages

1



Safe

No seals to leak. Double Containment, consisting of an inner stator liner plus an external stator pressure-containing shell, prevents leakage to the environment. This minimizes both immediate and long-term risks to personnel.

2



Low noise and low vibration

Totally enclosed with neither motor fans nor exposed bearings.

3



E-Monitor

Monitoring of bearing wear in real time.

4



Small, compact and self contained

The integral pump and motor makes efficient use of space. Installation costs are reduced with minimal foundation requirements. No couplings used, therefore no alignment required.

5



Low routine maintenance

No motor bearings to lubricate, no pump bearings to lubricate, no coupling alignment or lubrication, no buffer pots to fill.

6



Easy to assemble and to maintain

No shimming or clearance setting required. Simply by design, only few parts required.

Markets

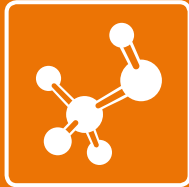

Chemical industry

Chemical transfer applications. Railcar unloading pumps. Nikkiso is one of the leading providers of seal-less hot oil pumps in industry.



Refineries

Handling alkylation chemicals (sulfuric or HF), NGLs, sour water, benzene, volatile hydrocarbons, LNG, and many other refinery applications.



Energy utilities

Seal water pumps. High pressure condensate. NOX suppression.

Specifications

Technical data

	Standard	Engineered
Max. Capacity	3,430 gpm (780 m ³ /h)	3,430 gpm (780 m ³ /h)
Max. Head	670 ft (300 m) single stage	1,640 ft (600 m) multistage
Fluid Temp. Range	-76 to 662 °F (-60 to 350 °C)	-328 to 842 °F (-200 to 450 °C)
Specific Gravity Range	0.3 to 2.0	Max. 13.6
Max. Viscosity	200 cP (200 mPas)	500 cP (500 mPas)
Max. Working Pressure	600 psig (4 MPa)	4500 PSI
Motor Power Range	0.5 to 268 hp (0.4 to 200 kW)	268 to 360 hp (200 to 270 kW)
Liquid End Material	316SS, 304SS	Alloy 20, Hastelloy C/B, Carbon Steel, (others available on request)

Automatic Thrust Balance

The hydrodynamic action of a set of fixed and variable orifices provides automatic thrust balancing to center the shaft between thrust bearings. This eliminates thrust bearing wear during normal operation. Contact between the replaceable thrust washers and the thrust face of the carbon bearings occurs only during start up and upset conditions such as loss of suction. By controlling thrust loads at the impeller, motor cooling flow is not affected by shaft position.

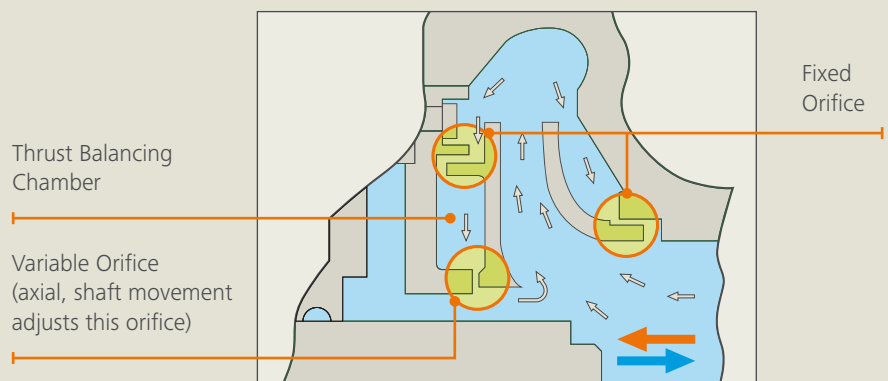

Examples

Volatile Liquids



Reverse circulation type pumps for pumping LNG as Cooling medium. (Vertical type, Motor output 75kw)

High Temperature Services



High-temperature type pump in a chemical plant.

Tank, Railcar Unloading



Self-priming type pumps in a paint manufacturing plant.

Jackets Required



High melting point type pump in a chemical plant.

Special Alloys



Basic type pumps in a water treatment plant. (Titanium casing & impeller)

General Purpose



Basic type pumps in a chemical plant.

E-Monitor

NIKKISO E-Monitor was developed to detect the condition of bearings of hermetically sealed pumps during operation. In order to achieve this, the position of the rotor is monitored while the pump is operating. Moreover, the E-Monitor is energized by power from the incoming motor leads and does not require additional wiring. As the E-Monitor is supplied with power from the motor terminal box there is no need for external cabling. Furthermore, the technical excellence of the E-Monitor is useful in predictive maintenance necessitated by bearing wear.

Indication:

- Wear of front or rear radial bearing
- Uneven wear of front or rear bearing
- Wear of front or rear axial bearing
- Power on (pump is operating)
- Direction of rotation (correct or incorrect)



E-Monitor

Shaft Sleeves

Available in a variety of surface treatments to suit the specific fluid application. Replace when bearings are changed for new wear surface and clearance.

Bearings

Available in a variety of materials to suit the specific fluid application.

Thrust Washers

Absorb thrust loads during upset conditions and provide back-up to hydraulic thrust balancing.

Stator Band

Rotor

Stator

Stator Liner

Impeller

High efficiency design, both open/closed configurations.

Flanges

150, 300, 600, and 900 lb. standard

Shaft

Available in several materials and configurations

Thermostats

Embedded in the hot spot of the windings for protection against overheating.

Rotor Sleeve

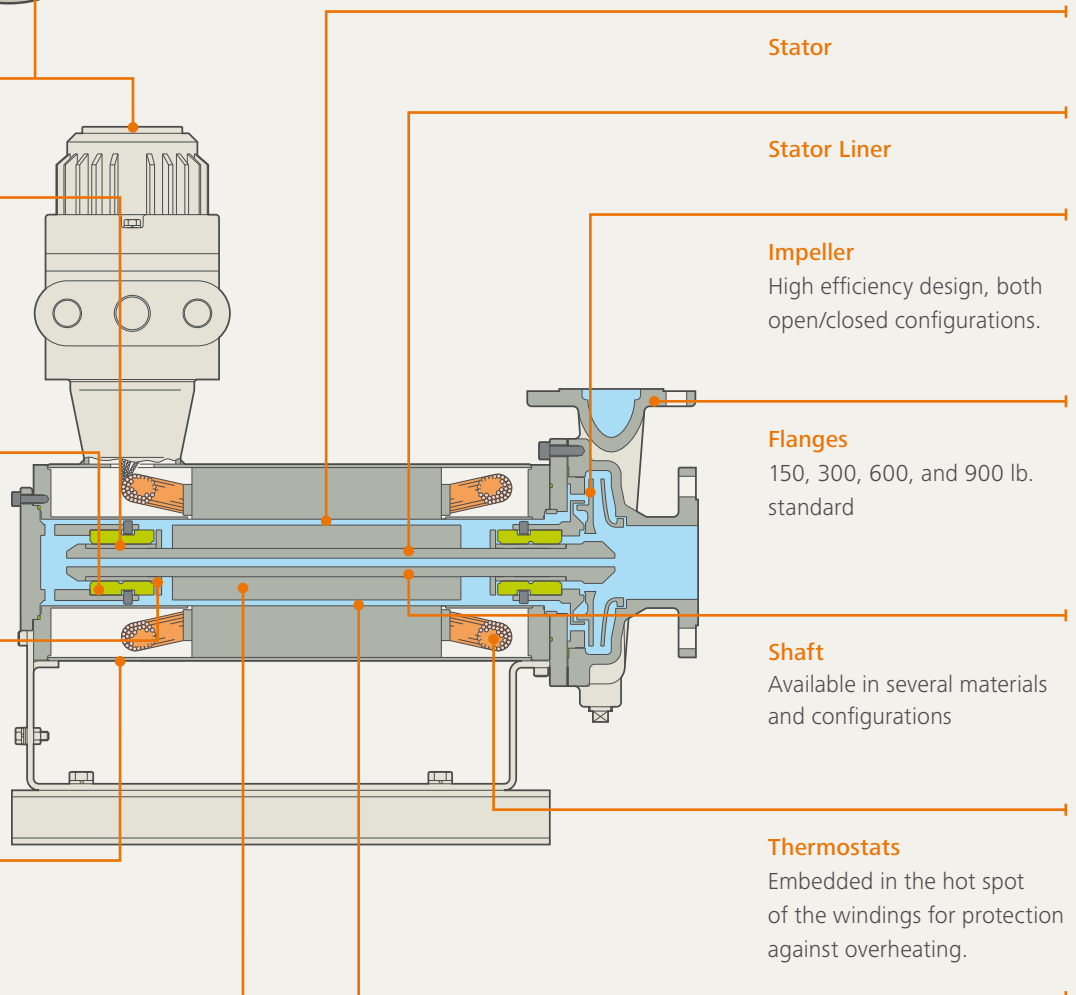

Principle of E-Monitor

The monitoring unit receives data from sensors embedded in the stator. When bearing wear occurs, the rotor assembly shifts along the radial and/or axial position. As soon as the rotor moves away from its desired position the measuring probes will

detect the change. After digital processing of the status change signals, the unit shows the operator the condition of the pump bearings, displayed on an easy-to-read LED display. The green LED indicates that everything is OK. An amber LED

warns the operator that the pump should be checked during the next regular plant shutdown. If the red LED lights up, the operator knows that the pump should be taken out of service and checked as soon as possible.

Indicator

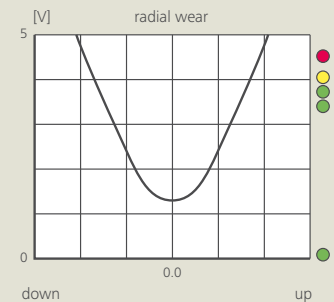
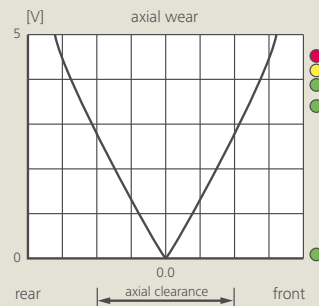

Bearing Modular System

Nikkiso bearings are sleeve type. Materials of construction range from various grades of carbon graphite, to PTFE, to silicon carbide. CG93, a hybrid carbon/silicon carbide mix, allows greater wear protection without brittleness.

Bearings are grooved to facilitate liquid lubrication. Bearings ride on a liquid film.

Shaft sleeves may be chrome coated or made of hardened material, depending upon your application.

Thrust washers (hard material or chrome coated) limit shaft travel in upset conditions to minimize the possibility of pump damage.

Bearings, sleeves, and thrust washers are identical on front and rear for easy installation.

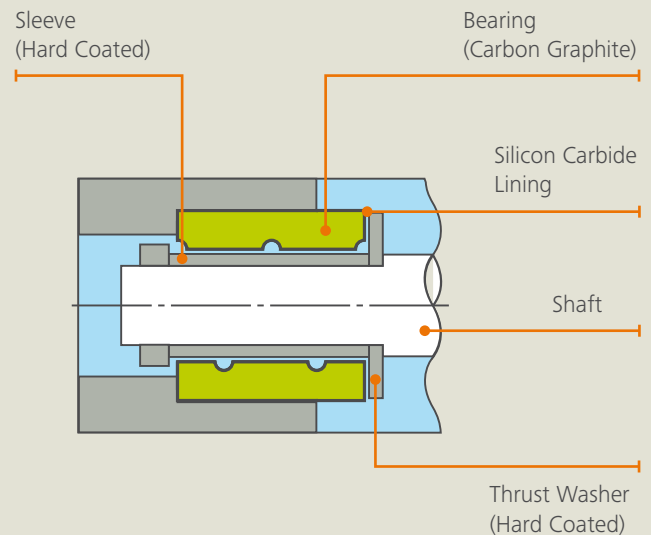

Motors

Reliable Motors

In the NIKKISO Non-Seal Pump design, the entire outside of the motor is enclosed in a secondary leakage containment shell or can. Primary leakage protection is provided by corrosion resistant liners which are seal welded and 100% leak checked to assure that pumped fluid does not contact the stator windings or rotor core. There is no mechanical seal to leak. Pumped fluid is circulated in the area between the rotor and stator liner to cool the motor and lubricate the bearings. Motor windings and insulation system are specially designed, developed and applied as an integral part of the pump so that design life is at least as great as that for conventional air cooled motors. Winding temperature is primarily influenced by pumped fluid temperature and secondarily by use of cooling jacket. Thermostats are embedded in the hot spots of windings for tripping off the motor in case of overheating.

Integration of the motor

Directly integrating the motor into the centrifugal canned pump not only ensures environmental protection but also safety at the plant. All parts of the pump are also designed for easy and fast maintenance. Therefore, you can minimize unproductive periods.



Head-capacity envelope

50 Hz

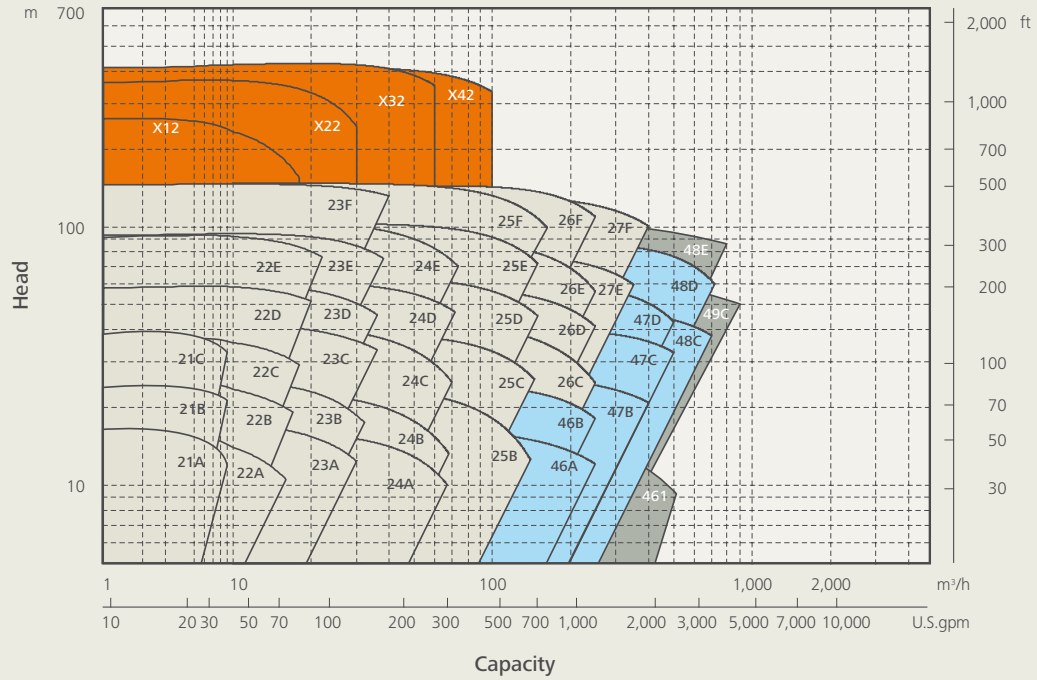

60 Hz

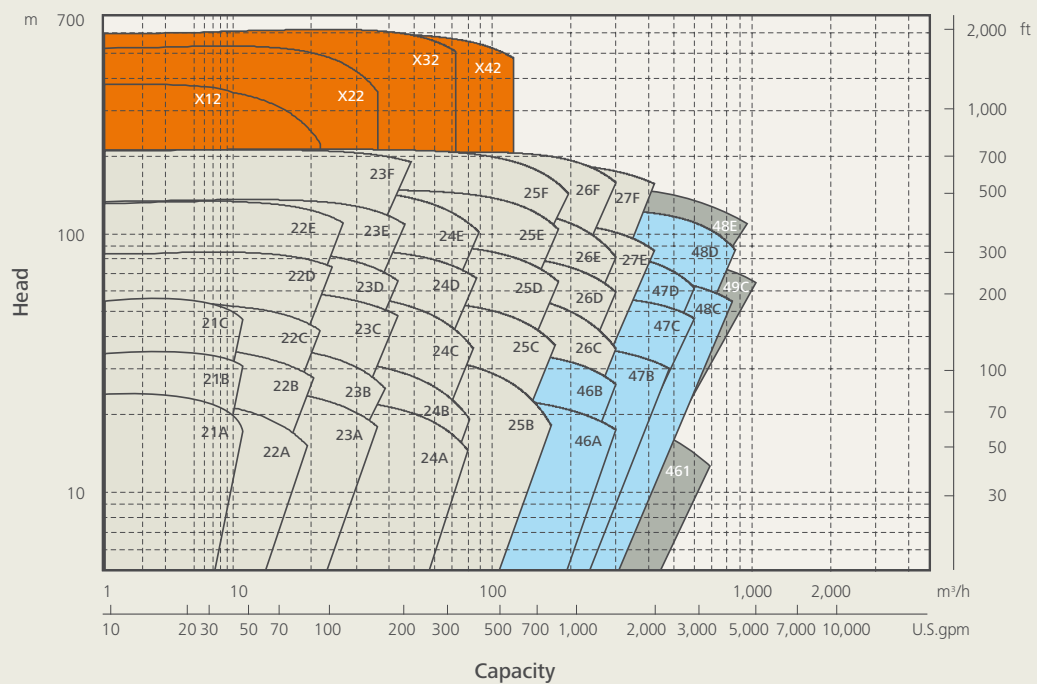

Standard Circulation

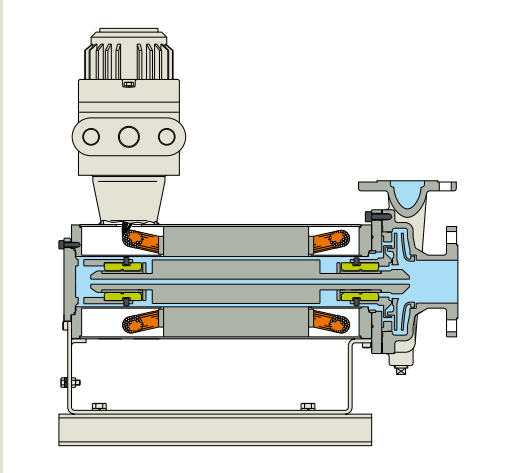

Type HN

Standard Pump

Suitable for a broad range of clean, nonvolatile liquids with moderate temperatures.

Capacity up to 3,430 gpm (780 m³/h)

Head up to 984 ft (300 m)

Motor up to 268 hp (200 kW)

Temperature -76 to +392 °F (-60 to +200 °C)

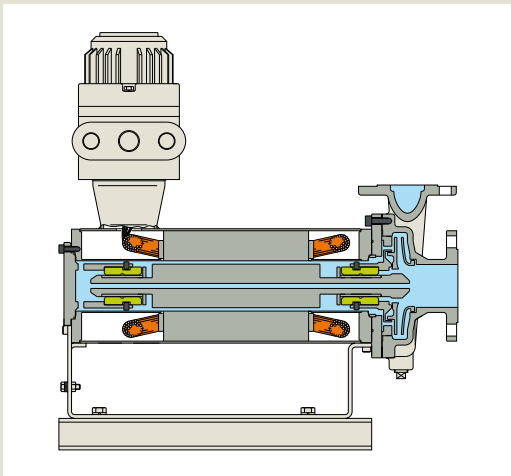

Type HV

High Viscous Liquids

Capacity up to 800 gpm (180 m³/h)

Head up to 660 ft (200 m)

Motor up to 59 hp (44 kW)

Viscosity up to 200 cP

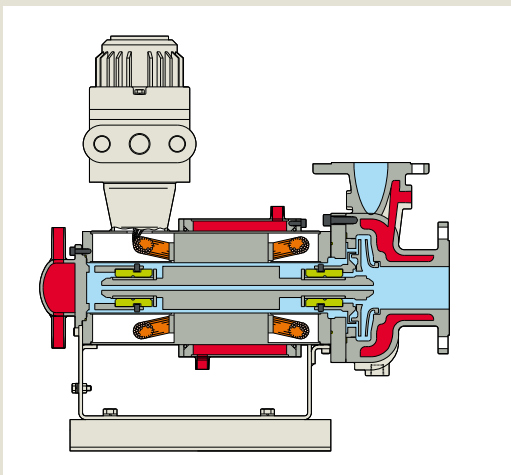

Type HB

Jacketed for High Melting Point Liquids

The type HB features complete jacketing of the pump case, motor stator and rear bearing housing for temperature control when handling fluids with melting points in the range of ambient to 285 °F (140 °C).

Capacity up to 700 gpm (160 m³/h)

Head up to 660 ft (200 m)

Motor up to 30 hp (22 kW)

Temperature up to 392 °F (200 °C)

High Temperature Liquids

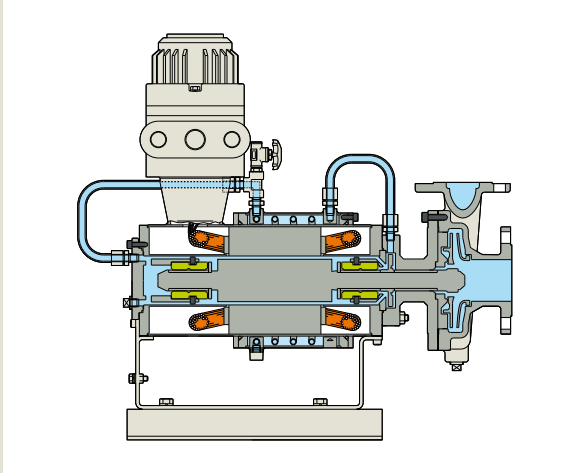

Type HT

High Temperature with Cooling

Designed for hot fluid applications. Process fluid is recirculated within the motor section via an auxiliary impeller. An integral shell and tube heat exchanger and thermal isolation spacer are provided to maintain cool fluid temperatures within the motor, maintaining an acceptable motor winding temperature.

Capacity up to 3,430 gpm (780 m³/h)

Head up to 984 ft (300 m)

Motor up to 268 hp (200 kW)

Temperature up to 752 °F (400 °C)

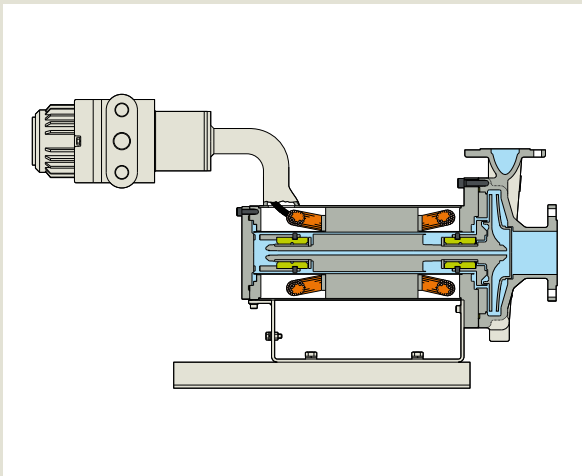

Type HX

High Temperature No Cooling Required

Heat Transfer System Service. The type HX utilizes an exclusive all ceramic motor insulation system and can be externally insulated for maximum system thermal efficiency, making it ideal for heat transfer oil services. Optional jacketing in conjunction with the ceramic motor insulation system makes the HX well suited for handling high melting point liquids (above 140 °C (285 °F)) which would exceed the temperature limit of normal organic motor insulation materials.

Capacity up to 880 gpm (200 m³/h)

Head up to 656 ft (200 m)

Motor up to 74 hp (55 kW)

Temperature up to 662 °F (350 °C)

Pumps for Slurries

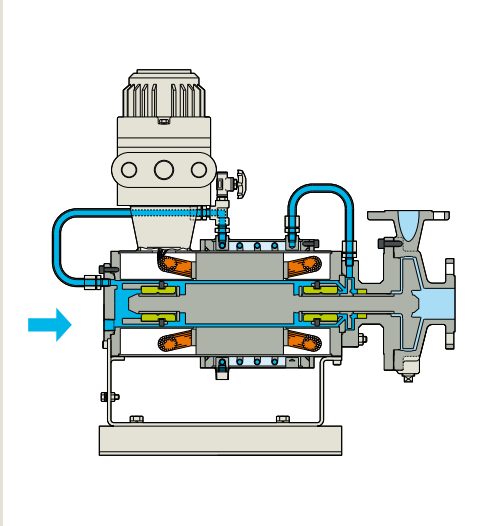

Type HS

Slurry Handling

A clean, compatible flush fluid supply is required and is constantly recirculated within the motor section to provide cooling and bearing lubrication and prevent solids or high vapor pressure liquids from migrating into the motor chamber. Recirculation is accomplished by use of an auxiliary impeller. An integral heat exchanger is provided to remove heat from friction and electrical inefficiency. Flush fluid loss to the process stream is minimized by a close clearance bushing between the motor and pump end. Although flush fluid is required (similar to conventional pumps with double seal) there is no shaft protrusion to seal and no seal to leak. Type HM is available utilizing a mechanical seal for reduced flush rates.

Capacity up to 3,430 gpm (780 m³/h)

Head up to 984 ft (300 m)

Motor up to 268 hp (200 kW)

Temperature up to 752 °F (400 °C)

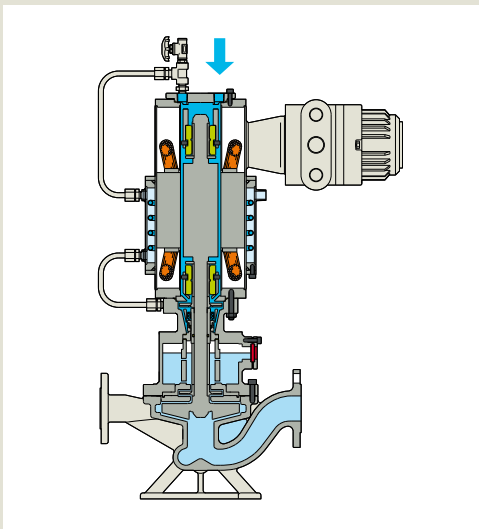

Type LG

High concentration of suspended solids

Vertical In-line type with mechanical seal gas chamber between pump casing and motor prevents damage to mechanical seal by solids.

Capacity up to 400 gpm (90 m³/h)

Head up to 260 ft (80 m)

Motor up to 30 hp (22 kW)

Additional Designs

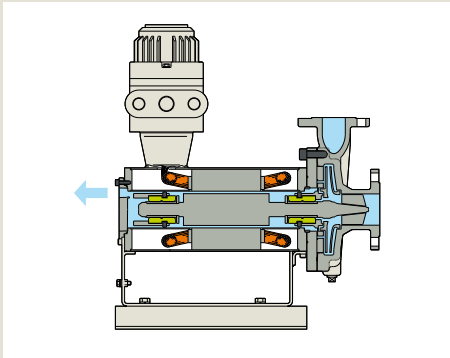

Type HQ

Reverse Circulation

Designed for fluids with steep vapor pressure curves which would tend to flash to vapor if returned to impeller eye after picking up motor heat. The type HQ utilizes a flow through the motor to the vapor zone of the suction vessel. The return line is throttled to maintain high pressure liquid within the motor and also serves as a vent line normally installed for this type of fluid.

Capacity up to 800 gpm (180 m³/h)
 Head up to 660 ft (200 m)
 Motor up to 59 hp (44 kW)

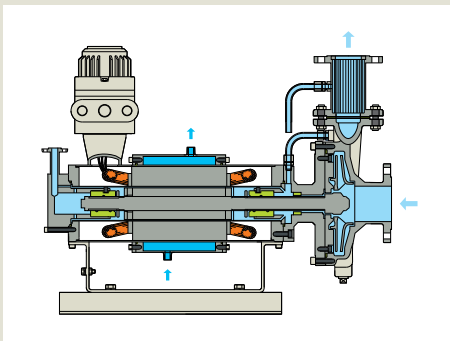

Type HR

Reverse Circulation

Design for fluids with the steepest vapor pressure curves. Type HR utilizes flow at full discharge pressure injected directly in to the bearing chamber. The return line is throttled to maintain high pressure liquid within the motor and also serves as a vent line normally installed for this type of fluid.

Capacity up to 3430 gpm (780 m³/h)
 Head up to 660 ft (200 m)
 Horsepower up to 177 hp (130 kW)

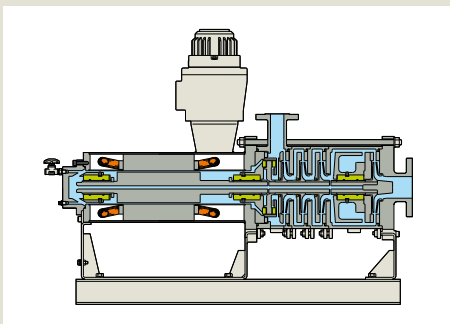

Multistage

High Head Pumps

Efficient operations in high head applications.

Capacity up to 530 gpm (120 m³/h)
 Head up to 1,640 ft (500 m)
 Motor up to 177 hp (132 kW)
 Temperature -22 to +302 °F (-30 to +150 °C)
 Viscosity up to 140 cP

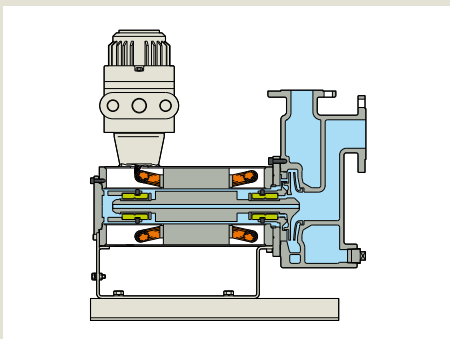

Type DN

Self Priming

Self priming volute casing without flap valve minimizes clogging troubles.

Capacity up to 790 gpm (180 m³/h)
 Head up to 230 ft (70 m)
 Motor up to 60 hp (45 kW)
 Temperature up to 338 °F (170 °C)
 Self Priming Head (Water 20 °C) up to 23 ft (7 m)

API 685 Canned Motor Pump

NIKKISO Canned Motor Pumps that comply with both API 685* and ATEX* are developed for the heavy duty requirements in the refinery and petrochemical industries.

*API 685: Sealless Centrifugal Pumps for Petroleum, Heavy Duty Chemical, and Gas Industry Services

*ATEX: ATEX Directive (94/9/EC)

E-Monitor

E-Monitor can indicate the axial and radial rotor position during pump operation on an easy-to-read LED display. Indication can be local or remote. Direction of Rotation LED for easy startup.

Temperature monitoring device for motor winding

Insulation class C allows un-cooled operation for fluid temperature up to 180 °C.

Temperature monitoring device for pump liquid

Additional temperature monitoring (optional)

Bearings

CG93 silicon/carbon bearings meet API bearing life requirements

Secondary containment

600 psi pressure capability standard

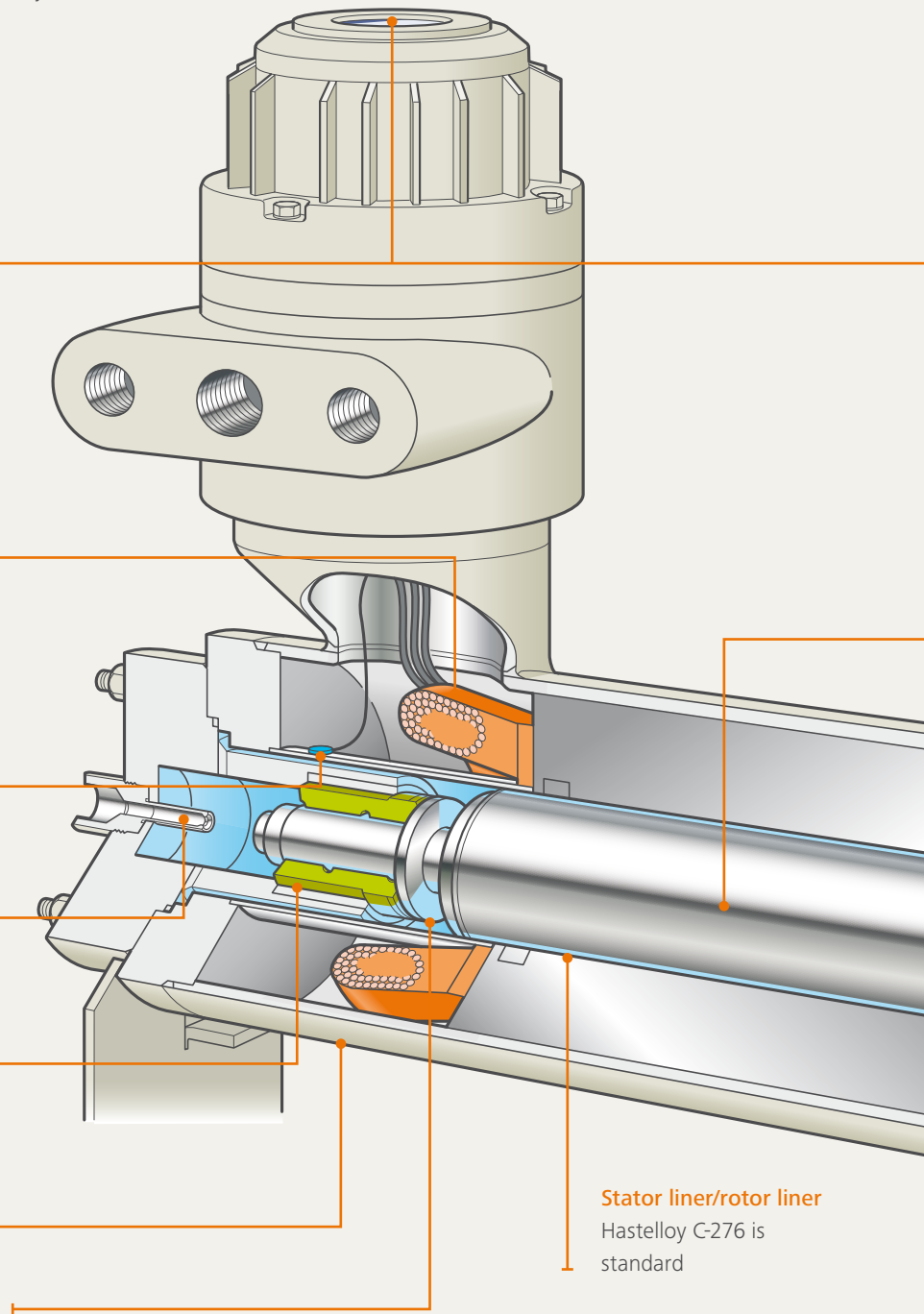

Shaft sleeves & thrust washers
ISO 1940, Gr. 2.5 gm-mm

Stator liner/rotor liner
Hastelloy C-276 is standard

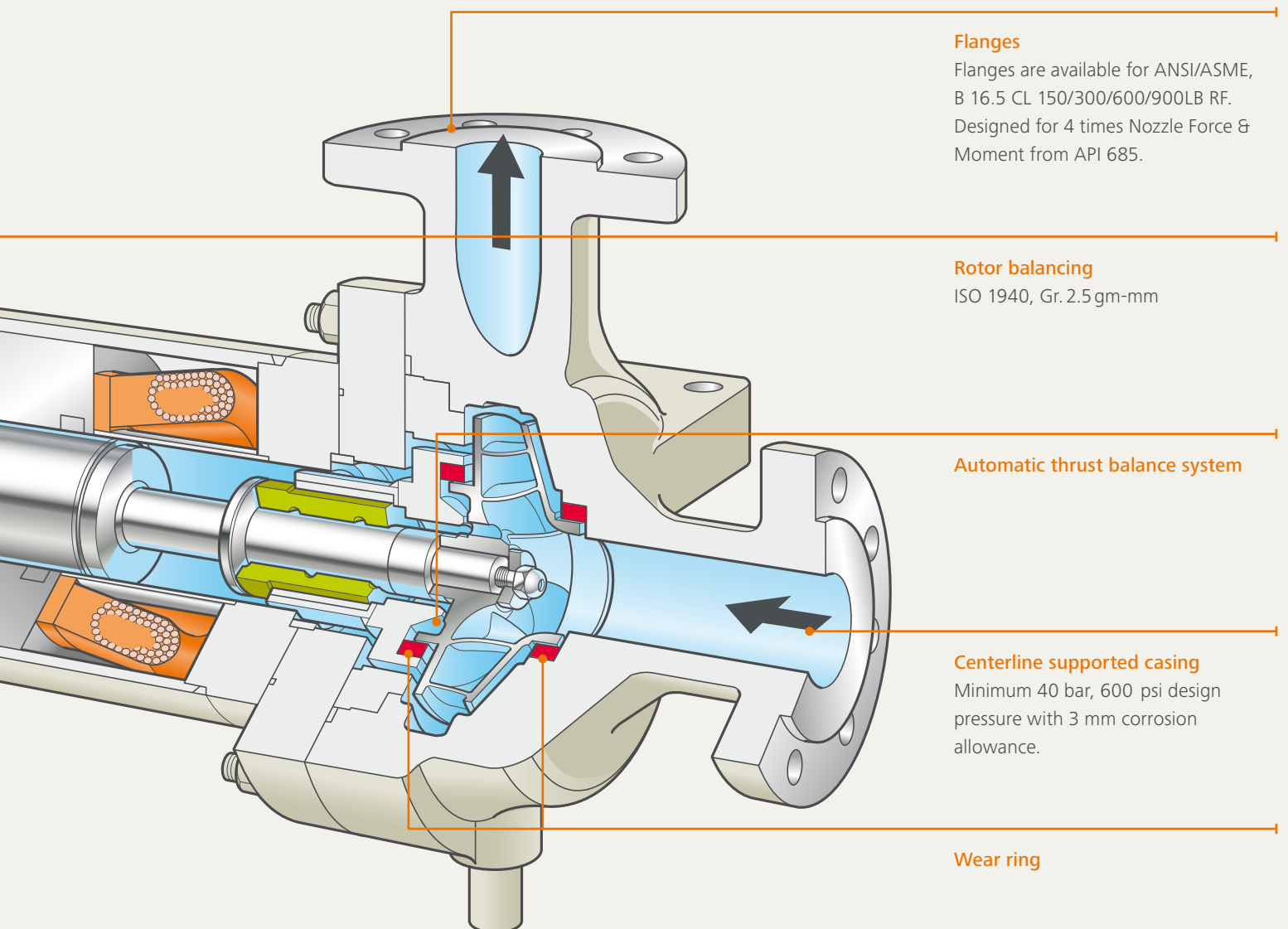
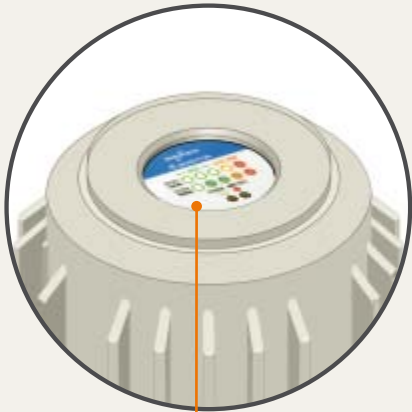

Flanges

Flanges are available for ANSI/ASME, B 16.5 CL 150/300/600/900LB RF. Designed for 4 times Nozzle Force & Moment from API 685.

Rotor balancing

ISO 1940, Gr. 2.5 gm-mm

Automatic thrust balance system

Centerline supported casing

Minimum 40 bar, 600 psi design pressure with 3 mm corrosion allowance.

Wear ring

Accessories



Remote indicator

This feature allows operator to see the E Monitor readout. Even in areas that are difficult to reach.



Dry operation protection (sao relay)

Load current sensing relay protects the pump from dry operation on services such as truck/tank car unloading. It detects low load resulting from dry operation and provides for shutdown of the motor.



Seal pot

Seal pot is available for type HM in order to supply flushing liquid to mechanical seal.



Inducer

Inducer is available for low minimum net positive suction head requirements (NPSHR).



Mechanical bearing monitor

The end of the monitor has a contact tip which is fitted within a cavity in the end nut on the rotor shaft. Clearances between the contact tip and the end nut correspond to the maximum allowable bearing wear. At maximum allowable bearing wear the tip is contacted and ruptured. In addition, the monitor is useful in detecting corrosion of the stator liner and rotor sleeve since the contact tip is supplied in the similar metallurgy by one-half the thickness of those components.

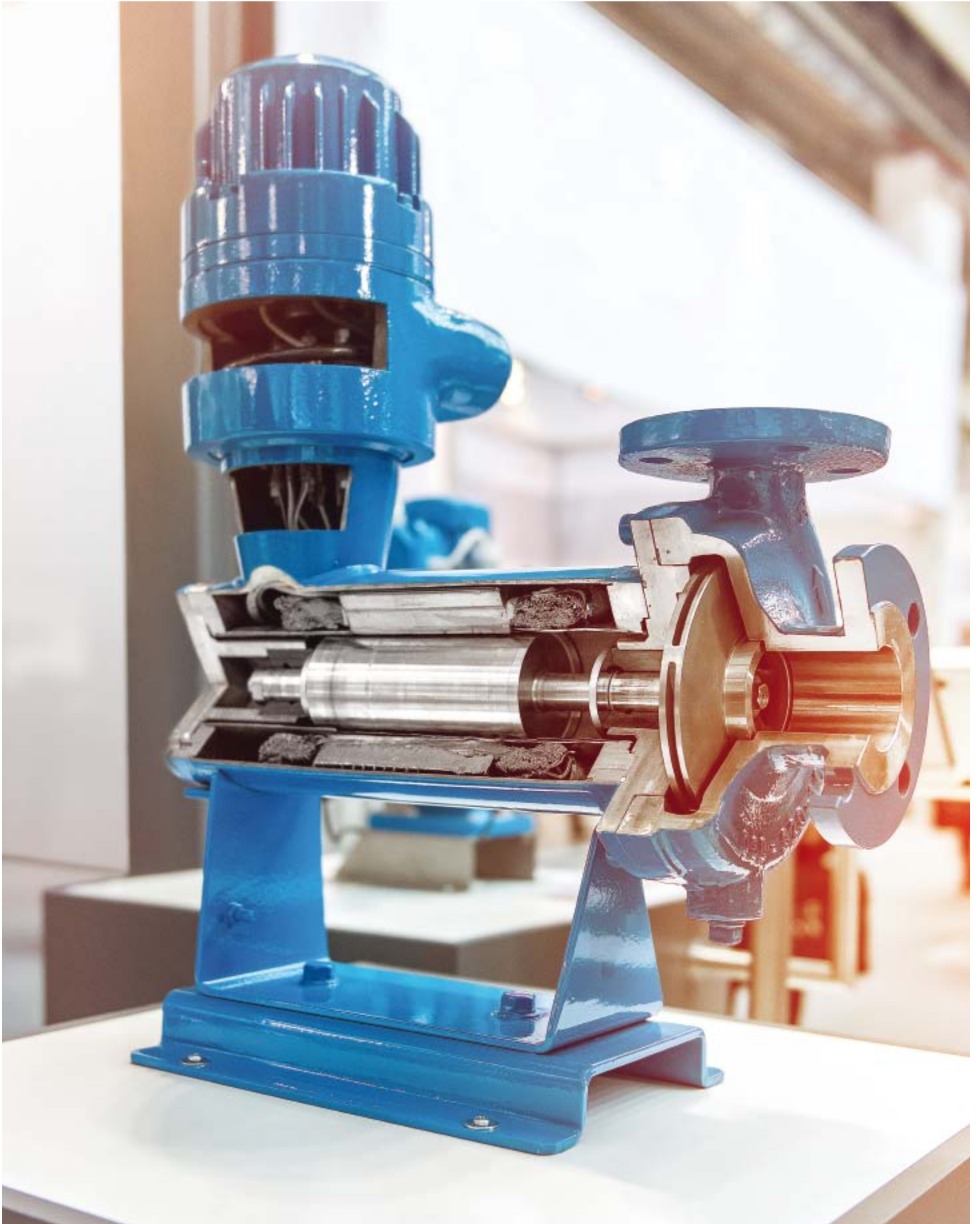

Regional Sales Offices

Alabama: +1 251 626-9010
Canada - Eastern: +1 724 288-7278
Canada - Western: 1 509 339-3662
Massachusetts: +1 508 429-7403
Pennsylvania: +1 724 288-7278
South Carolina: +1 713 502-3086
Texas: +1 713 577-5392
Washington: +1 509 339-3662
Wisconsin: +1 262 661-9133
Mexico: +52 1 55 5951-9609
Colombia: +57 311 262-8972

24 Hour

East Coast: +1 617 335-3836
West Coast: +1 281 796-7491

LEWA-Nikkiso America, Inc.

132 Hopping Brook Road
Holliston, MA 01746, USA
Phone: +1 508 429-7403
Fax: +1 508 429-8615

LEWA-Nikkiso America, Inc.

Gulf Coast Sales & Service Center
3433 N. Sam Houston Parkway West, Suite 400
Houston, TX 77086, USA
Phone: +1 713 577-5392
Fax: +1 713 577-5393

sales@lewa-inc.com
www.lewa-inc.com

Your local representative:

